



Read these instructions before installation and operation



**THIS EQUIPMENT MUST BE INSTALLED AND MAINTAINED BY A SUITABLY SKILLED AND TECHNICALLY COMPETENT PERSON. ENSURE ALL POWER IS REMOVED BEFORE INSTALLATION.**

## Product Description

The BF326 Range Mains Isolator Keyswitch (samples shown right) is a lockable, double-pole keyswitch unit that provides secure switching of the mains supply to either a fire alarm panel in accordance with BS 5839-1, an EVAC Alert panel in accordance with BS 8629 or an Emergency Voice Communication panel.

**N.B.** If the keyswitch is to be used for EVAC Alert Systems or Emergency Voice Communication Systems (EVCS) please fit the appropriate label to the front of the keyswitch (Order Code BF326/LABEL required).

The keyswitch can be flush or surface mounted dependent on the model purchased. Six variants are available as listed in Table 1 below:

**Table 1 - BF326 Range**

Order Code	Description
BF326/RF	Mains Isolator Keyswitch, Red, Flush
BF326/WF	Mains Isolator Keyswitch, White, Flush
BF326/RS	Mains Isolator Keyswitch, Red, Surface c/w back box
BF326/WS	Mains Isolator Keyswitch, White, Surface c/w back box
BF326/RSL	Mains Isolator Keyswitch, Red, Surface c/w LED & back box
BF326/WSL	Mains Isolator Keyswitch, White, Surface c/w LED & back box
BF326/LABEL	Mains Isolator Dual Label for EVAC ALERT SYSTEM & EVCS

**BF326/RSL**  
(c/w LED & Back Box)



**BF326/WSL**  
(c/w LED & Back Box)



**BF326/LABEL**

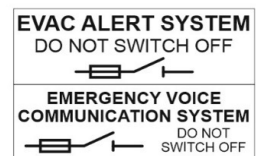

## Features

- BF326 switch type allows the mains supply to a fire alarm panel to be locked on and off (per BS 5839-1).
- Ideal for use during routine test and maintenance, e.g. battery tests and main board replacement.  
**N.B.** You must follow a procedure for safe isolation if you are going to work on the mains for the CIE.
- Versions supplied for use with Fire Alarm Systems, Evacuation Alert Systems (using BF326/LABEL) or Emergency Voice Communication Systems (using BF326/LABEL), allowing the installer to custom fit to suit a specific application.
- Can be surface mounted (using a supplied 1 gang back box) or flush mounted (fits on a standard UK 25mm deep back box).
- Available in a red or white enclosure with or without a green 'POWER' indicator.
- Double-pole switch with connections marked for L (Live), N (Neutral) and Earth.
- Lockable switch with key removed in the locked or unlocked position (a special key is only available to the responsible person).
- Fitted with an internal 5A fuse.
- Able to be wired with 1 x 2.5mm<sup>2</sup> cable or 2 x 1.5mm<sup>2</sup> cable to ensure only independent sole mains supplies are used to the fire panel as per BS 5839-1 requirements.
- Designed to comply with BS EN 60669-1 & BS EN 60669-2-4.

# Fig.1 - Typical Mains Circuit Configuration using the BF326

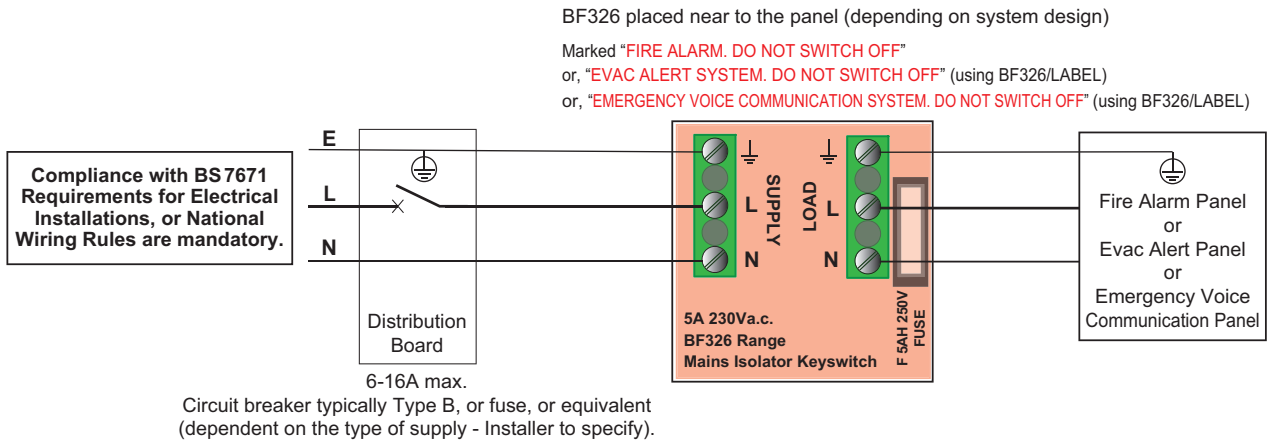

## BS 5839-1 Recommendations for Mains Supplies to Fire Panels and BS 8629 Recommendations for Mains Supplies to EVAC Alert Panels

The installer should read either BS 5839-1 Clause 25.2 or BS 8629 Clause 14.2 for complete details. The requirements of the IET Wiring Regulations (BS 7671), or applicable National Wiring Rules, are mandatory for all electrical installations.

The BF326 is a double-pole keyswitch that is designed to comply with BS EN 60669-1 (General requirements for switches for household and similar fixed-electrical installations) & BS EN 60669-2-4 (Part 2-4 Particular requirements - Isolating switches) and meets all construction requirements, allowing it to be installed in an electrical installation. It is also marked according to the requirements of BS 5839-1 or BS 8629 (depending on the application).

Switching off the mains using the keyswitch, allows you to safely perform all routine test and maintenance tasks at the control panel (battery test, main board replacement, etc.). Work on the mains electrical wiring to the CIE should only be carried out by suitably qualified persons who are competent to perform safe isolation of the equipment.

Please note that earth terminals are provided for installation convenience, these connections are not essential to the electrical safety or safe use of the BF326 isolator itself.

## Technical Specification

<b>Description:</b>	BF326 Range Mains Isolator Keyswitch, see Table 1 (page 1) for order codes		
<b>Standards:</b>	BS 5839-1 (Fire detection and fire alarm systems for buildings) BS 8629 (Evacuation Alert Systems) BS EN 60669-1 (Switches for household and similar fixed electrical installations, General Requirements) BS EN 60669-2-4 (Part 2-4: Particular requirements – Isolating switches)		
<b>Operating Voltage:</b>	230Va.c.		
<b>Quiescent Current:</b>	2.3mA (if LED fitted); 0mA (if LED not fitted)		
<b>Current @ 230V:</b>	5A (limited by internal fuse)		
<b>Switch Type:</b>	Double-pole, lockable on and off (per BS 5839-1)		
<b>Internal Fuse:</b>	5A ceramic fast blow (F 5AH 250V) High Rupturing Capacity		
<b>Key:</b>	C-TEC Red Plastic Fire Key (2 off supplied)		
<b>Keyswitch Position:</b>	Turn keyswitch to horizontal "I" position to switch on power; turn keyswitch to vertical "O" position to switch off power.		
<b>Indicator (if fitted):</b>	Green POWER LED lights when the keyswitch is in the horizontal "I" position - Order codes: BF326/RSL, BF326/WSL		
<b>Compatible Panels:</b>	All C-TEC mains control panels plus 3rd party single phase control panels if maximum load is 5A or less.		
<b>Dimensions (mm):</b>	Flush mounted: 86 W x 86 H x 25 D; Surface mounted c/w back box: 86 W x 86 H x 55 D.		
<b>Fixing Screws:</b>	M3.5 x 40mm (2 off supplied)	<b>Body Material/Colour:</b>	Red PVC RAL3001 or White PVC RAL9003
<b>Operating Temp.:</b>	-10°C to +40°C	<b>Weight:</b>	Flush mounted: 110g; Surface mounted: 170g
<b>IP Rating (EN 60529):</b>	IP30 (indoor use only)	<b>Humidity:</b>	Max. 95% RH (non-condensing)



Manufacturer: Computationics Limited (C-TEC), Challenge Way, Martland Park, Wigan, Lancashire WN5 0LD. [www.c-tec.com](http://www.c-tec.com)

E&OE. No responsibility can be accepted by the manufacturer or distributors of these devices for any misinterpretation of this instruction, or for the compliance of the system as a whole. The manufacturers' policy is one of continuous improvement and we reserve the right to make changes to product specifications at our discretion and without prior notice.