

GLORIA®

Die Marke für mehr Sicherheit



**Fluorine-free
fine spray mist extinguisher
with excellent spray duration**

**Water Fire Extinguisher
with Cool-Down-Effect
Suitable for Lithium-Ion Batteries**



Water fire extinguisher with Cool-Down-Effect

PRO-Line with strike-knob, extinguishing pistol and lance

The ace even for sensitive applications

Portable cartridge operated water fire extinguisher with very good ecological and maintenance-friendly characteristics, approved according to DIN EN 3 for fire class A. Due to the proven special suitability for burning lithium-ion batteries, the extinguisher can be used on batteries up to 642 Wh* (WKL 6 PRO) respectively 1285 Wh* (WKL 9 PRO) or with pouches up to 700 Wh (WKL 9 PRO).

Product features

- Laser-welded cylinder with durable inner coating
- Black anodised metal locking collar
- Perfect handling due to rotatable and extra-long LABS-free quality hose assembly with fabric insert made of synthetic rubber material.
- Rotatable and suppressible extinguishing pistol with pre-mounted extinguishing lance with 5-hole spray nozzle
- Extinguishing agent concentrate fluorine-free, without environmentally harmful PFOS or PFOA
- Conscious renunciation of substances in the water
- Blue colour code indicates extinguishing agent water
- Special suitability for lithium-ion batteries up to 642 Wh* (WKL 6 PRO) or 1285 Wh* (WKL 9 PRO), at pouches up to 700 Wh (WKL 9 PRO)

Application

- Users of products with lithium-ion batteries up to 642 Wh* or 1285 Wh* or of pouches up to 700 Wh (laptops, e-bikes, e-scooter, cordless, screwdrivers, etc.)
- Hotels, especially bicycle hotels
- Computer/electronic stores (including storage areas)
- Tool departments in retail companies
- File storages/archives/paper and packaging stores
- Offices
- Wood processing
- Textiles
- Municipal facilities
- Administrative and manufacturing areas
- Private households

* Tests were conducted on cell type 18650

Note

The suitability test on lithium-ion batteries was conducted by the Dutch institute KIWA!

i Example how to calculate battery size

Open Circuit Voltage: 19.5 V nominal
 Amp Hour Rating: 13 Ah
 Which gives us: 13 Ah* 19,5 V = 253,5 Wh

WKL 6 PRO is suitable for one battery up to 642 Wh
 WKL 9 PRO is suitable for one battery up to 1285 Wh



Type	Part No.	Extinguishing Agent / Qty.	Type	Propellant	Performance LE*	Discharge time / Discharge range	Temperature range	Use on lithium-ion (in Wh) Type 18650	H/W/D in bracket ø - cylinder Weight (kg)
WKL 6 PRO	9915/00	5,88 l Water + 0,12 l Imprex C	Strike knob and pre-mounted lance	60 g CO ₂	21A	65 sec. / 4 m	+5 °C to +60 °C	642 Wh	640/400/165 10,8 kg
WKL 9 PRO	9916/00	8,82 l Water + 0,18 l Imprex C	Strike knob and pre-mounted lance	120 g CO ₂	27A	80 sec. / 4 m	+5 °C to +60 °C	1285 Wh Pouches: 700 Wh	640/430/205 15,6 kg

Water fire extinguisher with Cool-Down-Effect

Spare parts and accessories

Do you need to replace a part or would you like additional accessories? Then you will find an overview of our spare parts and accessories here.

No.	TG PN	Description
1	22/151307	Strike knob
3	22/222036	Safety device, yellow
5	22/151310	Handle
6	22/151301	Spring pin
7	22/356711	Piercer (incl. o-ring(s))
8	22/149466	Spring
9	22/359992	Gas cartridge 60 g for 6 l (nonrefillable)
9	22/359741	Gas cartridge 120 g for 9 l (nonrefillable)
10	22/149422	Sieve for dip tube
11	22/151292	Dip tube 6 l
11	22/151293	Dip tube 9 l
12	22/201270	O-ring 60 x 4 NBR 70 Shore
13	22/151263	Locking collar, black aluminum
	22/148944	Safety clip, yellow
15	22/359990	Valve assembly for 6 l with gas cartridge, dip tube, agent cartouche
15	22/359991	Valve assembly for 9 l with gas cartridge, dip tube, agent cartouche
16	22/221827	Burst disc
17	22/359995	Hose assembly with pistol (mist nozzle)
19	22/211370	Skirt 6 l
19	22/211380	Skirt 9 l

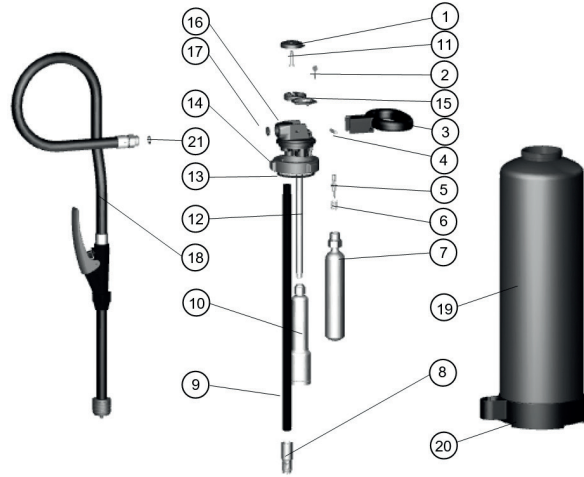

Lic.No.KM 280000

Extinguisher Identification Signage



150 mm x 100 mm

Rigid plastic
CS11208D

Photoluminescent rigid
plastic
CS31208D

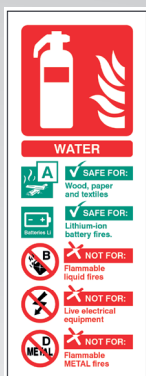

75 mm x 250 mm

Rigid plastic
CS11208S

Photoluminescent rigid
plastic
CS31208S

Brackets and Stands

Singular red stand
81/03694

Singular gray stand
81/03695

Wall bracket
GNB11114



GLORIA®

Die Marke für mehr Sicherheit

For more than seven decades, we have been the right contact for all questions regarding fire protection products. During this time, we have been able to gain a lot of experience, optimise our products, adapt them to today's requirements and continuously expand our team. We never lose sight of our origin, the fire extinguisher.

We offer a wide variety of models - from portable and mobile fire extinguishers to large fire extinguishing units. In addition, we are at home in the world of extinguishing water technology and object protection extinguishing systems. Our smoke and CO detectors, manufactured in our group, are highly reliable and stand out with manufacturer's warranties of up to 10 years. With our sophisticated range of accessories and spare parts, we create the safety you need. The portfolio is completed by both internal and external training courses and seminars.



Portable Fire Extinguishers



Extinguishing Water Technology



Mobile Extinguishers



Object Protection Extinguishing Systems



Vehicle Systems



Smoke detectors



**Accessories, Spare Parts,
Supplementary Products**



**Training, Seminars,
Information**



SOLD BY:

TG Products

**TG Products Limited
The Beehive, Suite 15C
Lions Drive, Blackburn, Lancashire, BB1 2QS
Phone +44 (0)1254 294 294**

tgsales@tgproducts.co.uk | www.tgproducts.co.uk