

E2xC1LD2R Combination Radial Horn & LED

The hazardous location E2xC1LD2R combined alarm sounder and LED beacon/status light is UL/cULs approved for Class I Div 2 and Class II Div 2 as well as IECEx and ATEX certified for Zone 2 and 22 applications.

The unique radial horn on the compact E2xC1LD2R distributes the audible warning signal omnidirectionally allowing the visual signal to be orientated optimally. The alarm horn offers a choice of 45 alarm tones and 3 remotely selectable stages. The LED beacon contains an array of 4 high output, multi-function L.E.D.s. with a total of 7 modes of operation – 5 flashing modes and 2 steady modes for use in indicator / status applications. The E2x range features enclosures manufactured from lightweight, corrosion proof GRP and high impact, fire retardant ABS re-entrant flare horns; both of which are suitable for the harshest of environments.

Features

- Corrosion proof PPS enclosure
- Ingress protection IP66/67, Type 4/4X
- Automatic synchronisation on multi-sounder systems
- Choice of five flash rates: 1Hz, 1.5Hz, 2Hz, double and triple flash.
- High and low power Steady modes
- Three remotely selectable stages/channels on DC versions.
- Glass lens & Stainless Steel guard
- UV stable PC field replaceable lens colour filter
- Dual cable entries – stopping plug included.
- Duplicate cable terminations (in & out for daisy-chain installations)
- Ratchet adjustable stainless steel 'U' bracket.

Approvals

- ATEX certificate: DEMKO 06 ATEX 0421554X
- IECEx certificate: IECEx ULD 14.0012X
- UL/cUL File ref: E230764
- UKCA certificate: UL21UKEX2135X
- Ex EAC certified: EAC RU C-GB.AA71.B.00273/20

Coding

- IECEx / ATEX:
 - II 3G Ex ec IIC T3 Gc Ta -20°C to +55°C
 - II 3D Ex tc IIIC T90°C Dc Ta -20°C to +40°C
 - II 3D Ex tc IIIC T105°C Dc Ta -20°C to +55°C
- NEC Class / Zone ratings US:
 - Class I Zone 2 AEx ec IIC T3 Gc Ta -20°C to +40°C
 - Zone 22 AEx tc IIIC T90°C Dc Ta -20°C to +40°C
 - Zone 22 AEx tc IIIC T105°C Dc Ta -20°C to +55°C
- CEC Class / Zone ratings Canada
 - Class I Zone 2 Ex ec IIC T3C Gc X Ta -20°C to +40°C
 - Class I Zone 2 Ex ec IIC T3B Gc X Ta -20°C to +55°C
 - Zone 22 Ex tc IIIC T90°C Dc Ta -20°C to +40°C
 - Zone 22 Ex tc IIIC T105°C Dc Ta -20°C to +55°C
- NEC & CEC Class / Division Ratings for US / Canada
 - Class I Div 2 Group ABCD T3C Ta -20°C to +55°C
 - Class II Div 2 Group FG T4A Ta -20°C to +55°C
 - Class II Div 2 Group FG T5 Ta -20°C to +40°C
 - Class III Div 1 & 2 Ta -20°C to +55°C



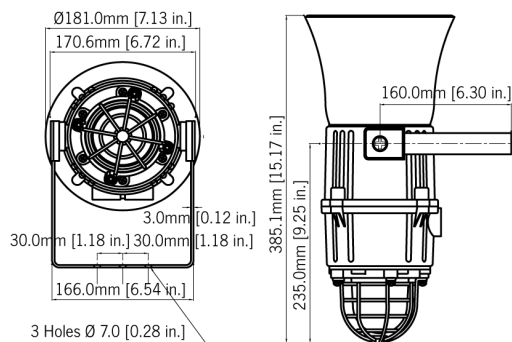

Specification

Alarm Horn:

Maximum output:	114dB(A) @ 1 metre [107dB(A) @ 10ft/3m]
Nominal output:	110dB(A) @ 1m +/- 3dB - Tone 2 [104dB(A) @ 10ft/3m]
No. of tones:	45 (UKOOA/PFEER compliant)
No. of stages:	3
Volume control:	Max. 113dB(A) Min. 105dB(A) - Tone 2
Effective range:	100m/328ft @ 1KHz

LED Beacon:

Source:	Array of 4 x High Power Cree® LED's
Modes:	1Hz flash (60 fpm) 1.5Hz flash (90 fpm) 2Hz flash (120 fpm) Double strike flash Triple strike flash High Power Steady Low Power Steady
Eff. Intensity cd:	87 cd - High Power Steady
Eff. Intensity cd:	160 cd - 1Hz flash
Voltages:	24V dc; 115V ac; 230V ac

General:

Voltages:	24vdc; 48vdc; 115vac; 230vac
Ingress protection:	IP rating per EN60079-0:IP64 IP rating per EN60529:IP66 Type rating per UL50E/NEMA250:4/4X/13
Enclosure:	UL94V0 GRP (PPS) & ABS
Lens material:	Borosilicate glass dome with PC prismatic lens.
Guard:	Stainless Steel dome guard as standard
Cable entries:	Dual M20x1.5 or 1/2"NPT
Terminals:	0.5 - 2.5mm ² (20-14 AWG)
Line monitoring:	Blocking diode included, EOL can be factory fitted
LED life:	60,000 hours
Operating temp:	-20 to +55°C [-4° to +131°F]
Storage temp:	-40 to +70°C [-40° to +158°F]
Relative humidity:	90% at 20°C [68°F]
Weight:	DC: 3.00Kg/6.6lbs AC: 3.50kg/7.7lbs

All candela data is representative of performance with clear lens at optimum voltage.

Part Codes

Part Code:	Ident.:	Description:
Product type:	E2xC1LD2	Combined alarm horn & LED beacon
Type:	R	Radial Omni-directional Horn
Voltage:	AC115 AC230 DC024	115V ac 50/60Hz 230V ac 50/60Hz 24V dc
Cable entries:[e]	A B C	M20x1.5 & ½" NPT M20x1.5 & M20x1.5 ½" NPT & ½" NPT
Stopping plug material: [m]	N	Nylon
Bracket & Guard & tag: [s]	1 2 3 4	304 A2 Stainless Steel 316 A4 Stainless Steel 304 A2 Stainless Steel & Equip. Tag 316 A4 Stainless Steel & Equip. Tag
Version: [v]	A1	UL, cULs, IECEx & ATEX
Enclosure: [x]	B	Black
Lens colour: [y]	A, B, C G, M, R Y	Amber, Blue, Clear Green, Magenta, Red Yellow
Accessories:	SP65-0001-A4 SP65-0003-A4	Pole Mount Bracket Kit 2" St/St A4 (316) Sunshade - St/St A4 (316)

Current Consumption

Version:	Voltage:	Alarm Horn Current:	LED Beacon Voltage:	Steady High Power:	Steady Low Power:	Flashing 1Hz:
				Power:	Power:	Power:
24V dc	+/-25%	265mA	18-54V	240mA	134mA	110mA
115V ac 50/60Hz	+/-10%	110mA	+/-10%	95mA	78mA	90mA
230V ac 50/60Hz	+/-10%	56mA	+/-10%	48mA	37mA	45mA

Tone table

S 1	Description	S 2	S 3	S 1	Description	S 2	S 3
T 1	340 Hz Continuous	T 2	T 5	T 33	745Hz @ 1Hz Intermittent	T 2	T 5
T 2	800/1000Hz @ 0.25 sec Alternating	T 17	T 5	T 34	1000 & 2000Hz @ 0.5 sec Alternating - Singapore	T 38	T 45
T 3	500/1200Hz @ 0.3Hz 0.5 sec Slow Whoop	T 2	T 5	T 35	420Hz @ 0.625 sec Australian Alert	T 36	T 5
T 4	800/1000Hz @ 1Hz Sweeping	T 6	T 5	T 36	500-1200Hz 3.75sec /0.25sec. Australian Evac.	T 35	T 5
T 5	2400Hz Continuous	T 3	T 20	T 37	1000Hz Continuous - PFEER Toxic Gas	T 9	T 45
T 6	2400/2900Hz @ 7Hz Sweeping	T 7	T 5	T 38	2000Hz Continuous	T 34	T 45
T 7	2400/2900Hz @ 1Hz Sweeping	T 10	T 5	T 39	800Hz 0.25sec on, 1 sec off Intermittent	T 23	T 17
T 8	500/1200/500Hz @ 0.3Hz Sweeping	T 2	T 5	T 40	544Hz (100mS)/440Hz (400mS) - NF S 32-001	T 31	T 27
T 9	1200/500Hz @ 1Hz - DIN / PFEER P.T.A.P.	T 15	T 2	T 41	Motor Siren - slow rise to 1200 Hz	T 2	T 5
T 10	2400/2900Hz @ 2Hz Alternating	T 7	T 5	T 42	Motor Siren - slow rise to 800 Hz	T 2	T 5
T 11	1000Hz @ 1Hz Intermittent	T 2	T 5	T 43	1200 Hz Continuous	T 2	T 5
T 12	800/1000Hz @ 0.875Hz Alternating	T 4	T 5	T 44	Motor Siren - slow rise to 2400 Hz	T 2	T 5
T 13	2400Hz @ 1Hz Intermittent	T 15	T 5	T 45	1KHz 1s on, 1s off Intermittent - PFEER Gen. ...	T 38	T 34
T 14	800Hz 0.25sec on, 1 sec off Intermittent	T 4	T 5				
T 15	800Hz Continuous	T 2	T 5				
T 16	660Hz 150mS on, 150mS off Intermittent	T 18	T 5				
T 17	544Hz (100mS)/440Hz (400mS) - NF S 32-001	T 2	T 27				
T 18	660Hz 1.8sec on, 1.8sec off Intermittent	T 2	T 5				
T 19	1.4KHz-1.6KHz 1s, 1.6KHz-1.4KHz 0.5s -NFC48-265	T 2	T 5				
T 20	660Hz Continuous	T 2	T 5				
T 21	554Hz/440Hz @ 1Hz Alternating	T 2	T 5				
T 22	544Hz @ 0.875 sec. Intermittent	T 2	T 5				
T 23	800Hz @ 2Hz Intermittent	T 6	T 5				
T 24	800/1000Hz @ 50Hz Sweeping	T 29	T 5				
T 25	2400/2900Hz @ 50Hz Sweeping	T 29	T 5				
T 26	Bell	T 2	T 15				
T 27	554Hz Continuous	T 26	T 5				
T 28	440Hz Continuous	T 2	T 5				
T 29	800/1000Hz @ 7Hz Sweeping	T 7	T 5				
T 30	300Hz Continuous	T 2	T 5				
T 31	660/1200Hz @ 1Hz Sweeping	T 26	T 5				
T 32	Two T chime.	T 26	T 15				