

REACH Wireless®

Open-Area Wall Sounder



Product overview

Product	REACH Wireless Open-Area Wall Sounder
Part No.	RW1500-110APO (White Body) RW1500-120APO (Red Body)
Digital Communication	Apollo protocol compatibility is handled via the Loop-Interface device, RW1700-030APO. See product for more detail.

Approvals



Product information

The RW1500-110APO and RW1500-120APO comprise of a wireless addressable interface and conventional open-area wall sounder that can be used as a stand-alone notification device.

- Compatible only with REACH Wireless
- 16 tone pair settings (primary and secondary for alert and evacuation), selectable via on-board DIL Switches
- Four Volume Settings
- Bi-directional wireless communication
- Dual channel redundancy
- Five year battery life
- Five year product warranty

Technical data

All data is supplied subject to change without notice. Specifications are typical at 24 V, 25°C and 50% RH unless otherwise stated.

Number of Tone Pairs	16 (see table 2)
Volume Levels	Four (see table 3)
Sound Output (Typical)	88 - 91 dBA (tone dependant)
Communication Range between Loop-Interface and Devices	100 m (in open space)
Field Device Radio Frequency Channel Pairs	22 pairs
Radiated Power	14 dBm (25 mW)
Battery Type	2x VARTA CR123A Lithium 3 V, 1250mAh typical
Battery Lifespan	Five years in normal operation with good signal strength (no dropped messages)
Operating Temperature	-10°C to +55°C
Maximum Relative Humidity (non-condensing)	95%
IP Rating	IP 35 (Type B Indoor Use)
Standards and approvals	EN54-3, EN54-25
Dimensions	126 mm diameter x 132 mm height x 125 mm depth
Weight (including base and batteries)	350 g

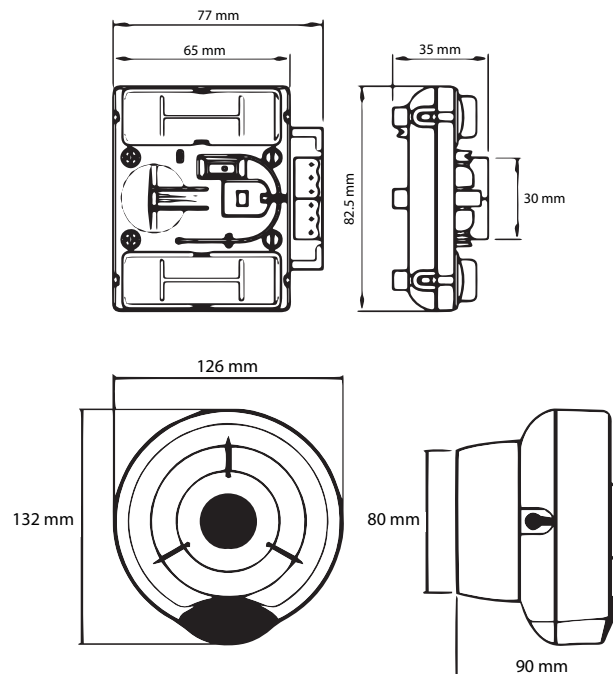

Status LED

The REACH Wireless Open-Area Wall Sounder VAD Base includes a 360° LED indicator which to indicate status conditions. See table 1.

Table 1: REACH Wireless Device Status & LED Indication

Device Status	LED Indication	
	Tamper Not Activated	Tamper Activated
Power Up	Blinks green four times	
Power Up (dip-switch ON)	Blinks red four times	
Entering Wake-Up	Blinks alternatively green/red four times	
Link Success	Blinks green four times, then repeats	
Link Failure	Enters wake-up mode and signals 'Entering wake-up mode' following this failure	
Normal Condition	LED off	LED off
Activation	LED off	Red on
Battery Faults	LED off	Amber blinking every 5s
Tamper Fault	LED off	
Replaced	Blinks amber two times	

Tone & Volume Selection DIP Switch Settings

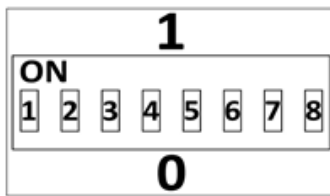

Device Addressing

Device addressing is handled by the REACH Wireless Loop-Interface device (RW1700-030APO).

Devices are soft-addressed automatically when pairing with the Loop Interface and can be changed manually. Hard-addressing using Apollo XPERT cards are not supported.

Table 2: REACH Wireless DIP Switch Functionality

DIP Switch Number	DIP Switch Group Function	Notes
1	Tone Selection	Check Tone Table (Table 4)
2		
3		
4		
5	Volume Selection	Check Volume Table (Table 3)
6		
7		
8	High/Low Power LED Output	N/A

Table 3: REACH Wireless Volume Table

Volume	DIP Configuration
High*	11
Medium High	01
Medium Low	10
Low	00

*EN54-3 certified, for Tone Table (Table 4), see appendix

Communication

REACH Wireless Devices use 'radio-frequency' wireless communication to connect to the Loop-Interface.

The Loop-Interface (RW1700-030APO) translates the wireless communication into wired Apollo protocol communication, with each device addressable individually by the fire panel. See datasheets for the Loop-Interface for more information.

Maintenance and Service

Maintenance must be performed in accordance with all applicable standards. Clean the detector externally using a soft damp cloth. For full cleaning and recalibration detectors should be returned to Apollo Fire Detectors.

Batteries

REACH Wireless devices are supplied with two CR123 batteries, battery A and B. The device switches periodically between the two batteries on a controlled sequence. For correct operation of the device, both batteries are required with adequate capacity reserves.

When battery A reaches a low power threshold, it will trigger a fault. This fault requires both batteries to be replaced in every instance as both batteries should be discharging equally.

When one (or both) batteries lack power, the Loop-Interface receives a low battery message and will signal this event on its in-built display, as well as relay the low battery message to the fire control panel. The battery fault will also be signalled by the device itself through its LED indicators if programmed (see table 1).

Tamper detection

REACH Wireless devices contain an anti-tamper mechanism. In the event of removal from its base, it sends a tamper detection message to the Loop-Interface.

Tampering detection is not signalled visually by the device LED.

EMC Directive 2014/30/EU

REACH Wireless Open-Area Wall Sounder complies with the essential requirements of the EMC Directive 2014/30/EU, provided that it is used as described in this datasheet.

A copy of the Declaration of Conformity is available from Apollo on request.

Construction Products Regulation (EU) 305/2011

The REACH Wireless Open-Area Wall Sounder complies with the essential requirements of the Construction Products Regulation (EU) 305/2011

A copy of the Declaration of Performance is available from Apollo on request.

Table 4: Tone Table

Apollo Tone Pair Number <i>Apollo Approved Tone</i>	DIP Switch Value	Primary Tone (Evacuation)			Secondary Tone (Alert)		
		Temporal Pattern Icon	Temporal Pattern Description	Frequencies	Temporal Pattern Icon	Temporal Pattern Descriptions	Frequencies
1*	0000		Apollo Fire Systems Evacuate Tone	660Hz for 0.5s, 925Hz for 0.5s		Apollo Fire Systems Alert Tone	1s off, 925Hz for 1s
2*	00001		Alternating Warble (Hechiki & Fullen)	925Hz for 0.25s, 624Hz for 0.25s		Continuous (Hechiki & Fullen)	925Hz
3*	00010		Sweep (med) @ 1Hz	800Hz - 970Hz @ 1Hz		Continuous	970Hz Continuous (BS5839-1:2002)
4*	00011		Sweep (fast) @ 9 Hz	2500Hz-2850Hz @ 9Hz		Continuous	2850Hz continuous
5*	00100		Netherlands - NEN 2575:2000 (Dutch Slow Whoop)	500 - 1200Hz for 3.5s, 0.5s OFF		Continuous	825Hz continuous
6*	00101		German DIN 33 404	1200Hz - 500Hz Sweep 1s (1Hz)		Continuous	825Hz continuous
7*	00110		Swedish Fire Signal	660Hz 0.15s ON, 0.15s OFF		Swedish All Clear	660Hz Continuous
8	00111		Australia Fast-rise Sweep (AS1670:4-2004, Evacuation tone)	3x (500Hz - 1200Hz for 0.5s, 0.5s off), 1s OFF		Australia AS1670:4-2004 Alert tone	420Hz, 0.625s ON, 0.625s OFF
9	01000		New Zealand Slow-rise Sweep Evacuation Tone (NZS 4512)	500Hz - 1200Hz, 3.75s Sweep, 0.25s OFF		New Zealand Alert Tone (NZS 4512)	420Hz, 0.625s ON, 0.625s OFF
10	01001		US Temporal LF (ISO 8201 Low Tone)	3x(970Hz 0.5s ON, 0.5s OFF), 1s OFF		Continuous	970Hz Continuous
11	01010		US Temporal HF (ISO 8201 High Tone)	3x(2850Hz 0.5s ON, 0.5s OFF), 1s OFF		Continuous	2850Hz continuous
12	01011		Simulated Bell - Continuous	827Hz for 16ms followed by 990Hz for 16ms.		Simulated Bell - Intermittent	827Hz for 16ms followed by 990Hz for 16ms for 1s then 1s off.
13	01100		Emergency Warning Siren	600Hz - 1200Hz 4s followed by 1200 - 600Hz 4s		Emergency Warning Siren All Clear	1200Hz Continuous
14	01101		France - AFNOR NF S 32 001	554Hz, 0.1s, 440Hz, 0.4s		Continuous	970Hz Continuous
15	01110		Australia Evacuation (AS7240-3)	520Hz, 0.5s ON, 0.5s OFF x 3, 1s OFF		Australia Alert (AS7240-3)	520Hz +/- 5%, 0.5s ON, 3.5s OFF
16	10000		Silent Tone (REACH Wireless ONLY)	0Hz Continuous		Silent Tone (Reach Wireless ONLY)	0Hz Continuous